



SPECIALIZED

by *Eberhardt*

TT Bastard 160



Don't tumble
anymore.



Bastarise your
product!

Competence since 1970

Eberhardt is one of the best known names for food press systems. From long-standing tradition and passion, the advancement in mechanical engineering has grown.

Eberhardt machines and production solutions have established worldwide. Quality and service is the heart of Eberhardt and our promise to our costumers.

Eberhardt GmbH

Awarded

TOP 100 Innovator 2024

Eberhardt earned this award from compamedia, recognizing our leadership in innovation among German SMEs. It highlights our contribution to advancing the food pressing industry.



Bavarian Excellence Award 2020

The Free State of Bavaria honored Eberhardt with a top 50 ranking in 2020. This accolade acknowledges our significant role in Bavaria's economy and manufacturing sector.



Ansbach District Innovation Award 2019

In 2019, we received the Ansbach District Innovation Award for our pioneering achievements in food processing technologies, setting new industry standards.



Gold Awards for FOOD PRESS SYSTEMS® Products

Our FOOD PRESS SYSTEMS® have produced gold award-winning ham and bacon products, demonstrating our commitment to quality and supporting our customers' success.



A strong connection

The Eberhardt TT Bastard 160 guarantees short processing times for injected or premixed products made from red meat, poultry, or fish.

The system ensures optimal protein extraction, resulting in strong binding and perfect product shaping. When combined with Eberhardt food press systems, it delivers maximum yield and excellent slicing results – ideal for demanding production environments.

Ideal
for toast ham,
shoulder ham
or poultry products

Suited
for mince
or tenderised
products



Advantages



Efficiency

Processing time 4 seconds

Short installation time

Avoidance of unneeded storage of products during the production process



Adaptability

For injected or premixed materials

Individual setting modes

Suitable for any operation due to its low space requirements



Quality

Optimal extraction of proteins

Easy accessibility

Hygienic design

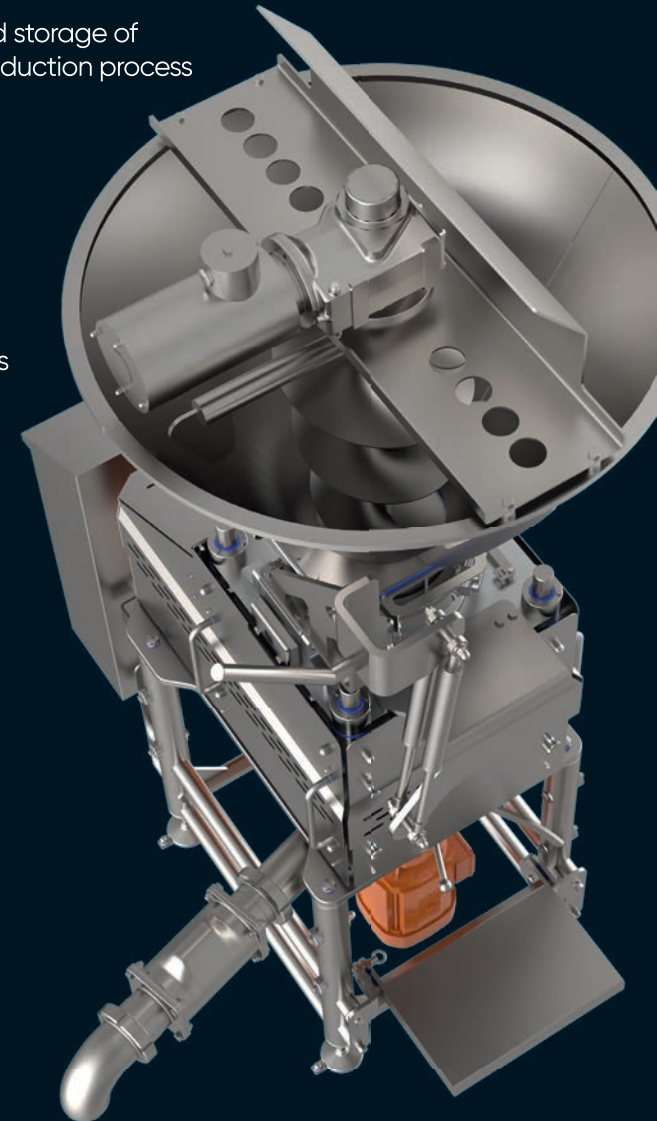

Efficient automation

In automatic mode, users can choose from up to 20 pre-set programs, with optional start-stop automation for added process control. All functions are managed via an intuitive touch display, allowing for easy setup and reliable operation.

Dual Drive for high performance

Equipped with frequency-controlled geared motors and a dual-drive system, the machine offers independent control of speed and direction, ensuring precise adaptation to different product types. The main motor is driven via a ribbed belt for optimal performance, while the internal motor regulates throughput.

A pneumatically controlled outlet valve supports continuous, pulsating, or time-controlled discharge modes – ideal for products with varying viscosities.



Eberhardt

TT BASTARD 160



1
Pneumatic opening of the entire machine for removing and changing the rotors.



2
Tool-free opening of the folding hopper.

The Bastard in Numbers

2.4m²

FOOTPRINT

9x

OUTPUT VS. REGULAR TUMBLER

100%

MADE IN GERMANY



The Bastarised Product

Efficient and gentle tumbling and massaging

The compact, space-saving design ensures high efficiency, while the adjustable feed screw enables continuous product flow.

The system can be used as a stand-alone unit or integrated into an automated production line.

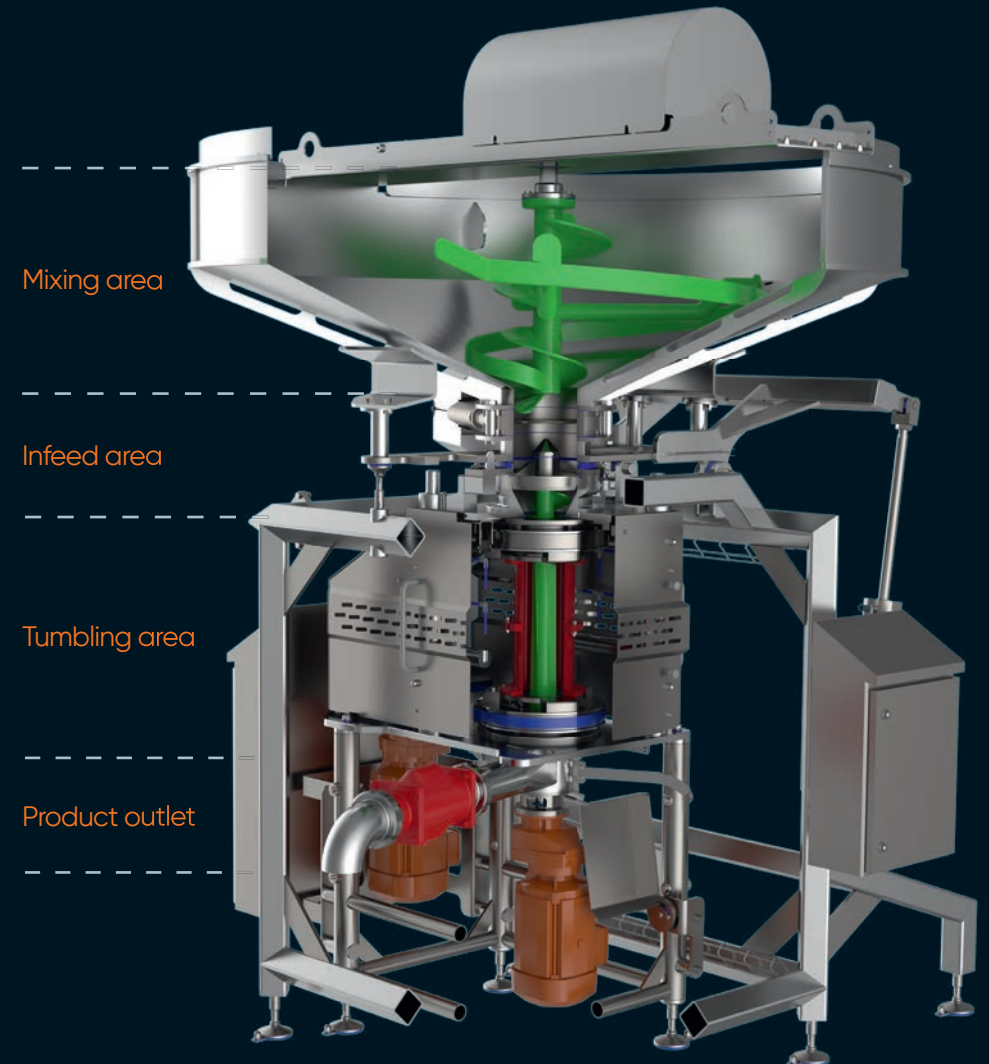

Additional options

Eberhardt provides various additional options for the Eberhardt TT Bastard 160, such as column loading and pre-mixing of products, to further optimize the production process.

With the PreMix 200 and PreMix 1000, the individual components are pre-mixed before being processed further in the TT Bastard 160.

These additional options ensure even more efficient and precise product processing.



Efficient mixing of all components

All individual ingredients are evenly mixed, ensuring consistent high quality and uniformity of the final product.

Efficient product loading

Eberhardt column loading allows quick loading of preinjected or premixed product.



Optimize your production with our customized production line

Increase the efficiency and precision of your manufacturing with our innovative line solutions.

Eberhardt offers customized systems specifically designed to meet your production requirements.

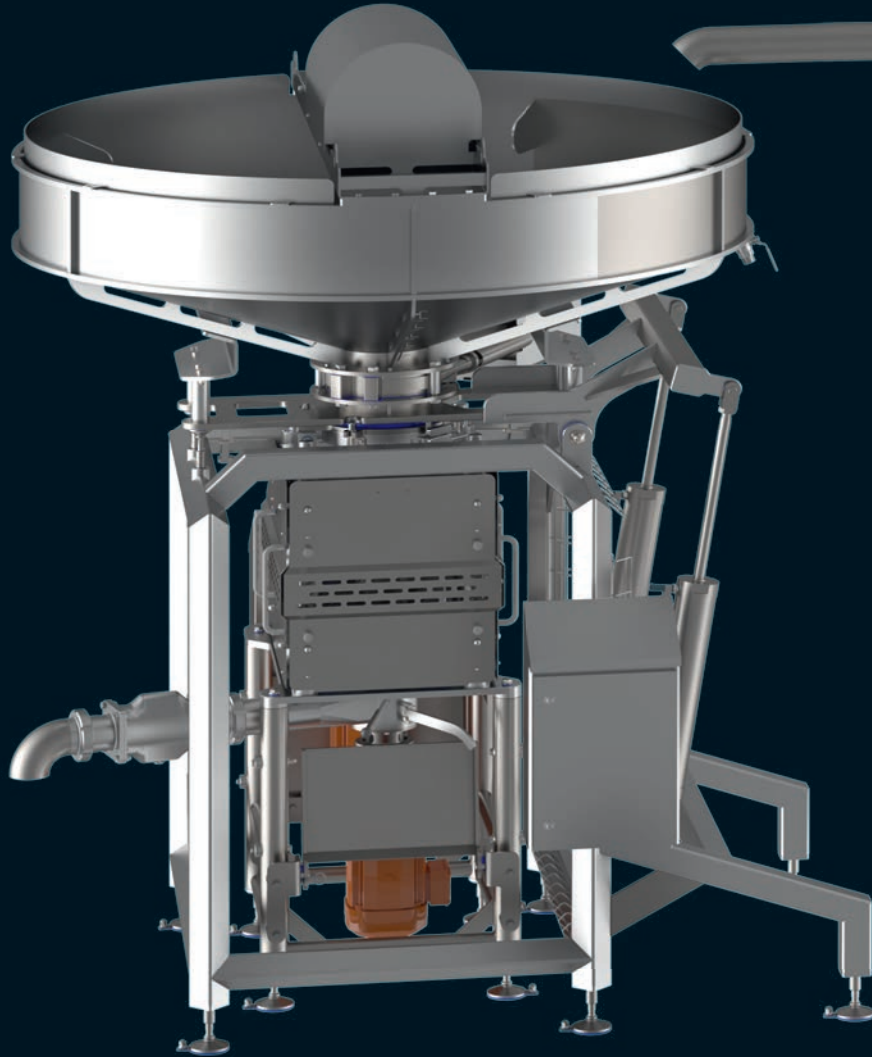

TT BASTARD 160 + PREMIX 1000

PreMix 1000 including pre-pump

Efficient pumping for high-performance processing

This pump offers high capacity with a minimal footprint and efficiently handles small particles at high injection rates across different pump distances.

Perfect for premixed products, small particles and high injection rates

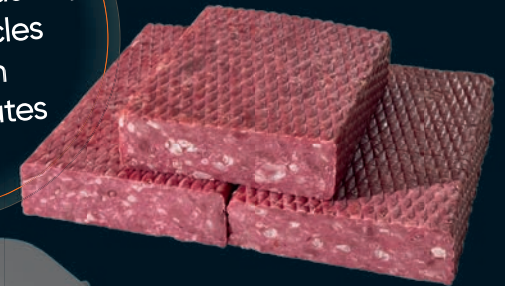

PRE-PUMP

PREMIX 1000

PreMix 1000 with screw conveyor

The right transportation for your product needs

Gentle transfer of marinated products or whole muscle pieces. The screw conveyor is fully adjustable in speed and guarantees damage-free transport.



Perfect for marinated products, full muscle, bone in, injected and fish

TT BASTARD 160 + PREMIX 1000

SCREW CONVEYOR

PREMIX 1000

PreMix 200



Technical Data PreMix 200

Width x depth x height	1700 x 1400 x 2300 mm
Total weight without options	approx. 830 kg
Outlet height	705 mm
Electrical supply	400V – 50Hz – 32A
Pneumatic supply	¼" – 6 bar – 150 l/h

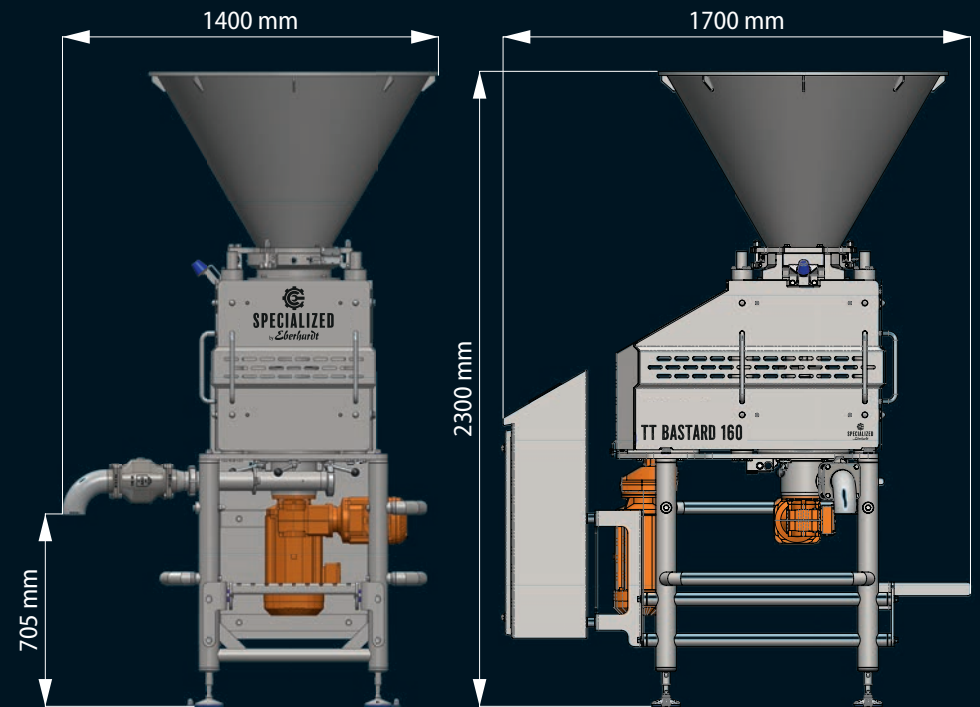

PreMix 1000



Technical Data PreMix 1000

Width x depth x height	2101 x 2520 x 3368 mm
Total weight without options	approx. 1600 kg
Outlet height	714 mm
Electrical supply	400V – 50Hz – 32A
Pneumatic supply	¼" – 6 bar – 150 l/h

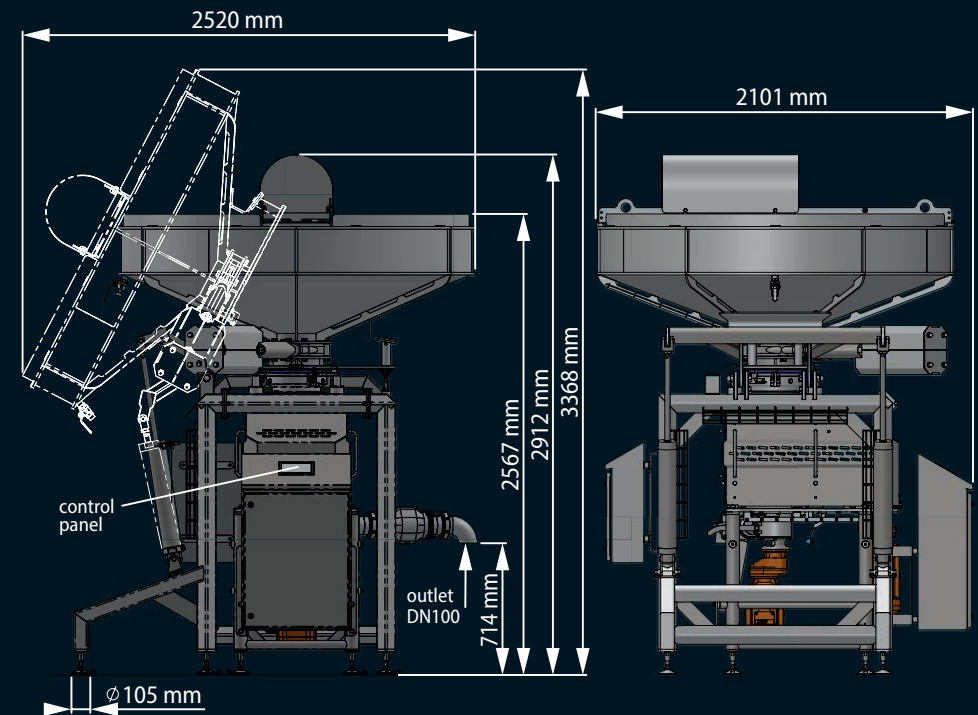

I am a
BASTARD.



SPECIALIZED
by *Eberhardt*



Eichendorffstraße 5, 91586 Lichtenau, Germany

 +49 9827 92838-0

 info@eberhardt-gmbh.de

 www.eberhardt-gmbh.de